



Internal Use Only

website:<http://biz.LGservice.com>

PLASMA TV

MANUAL DE SERVIÇO

CHASSIS : PP81A

MODELO : 42PG20R

42PG20R-MA

ATENÇÃO

Antes de reparar este chassis, leia as PRECAUÇÕES DE SEGURANÇA contidas neste manual.

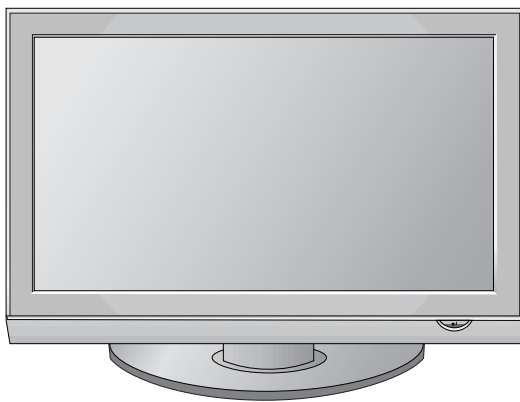

CONTEÚDO

CONTEÚDO	2
PRECAUÇÕES DE SEGURANÇA	3
INSTRUÇÕES DE REGULAÇÃO	4
DIAGRAMA DE BLOCOS	12
VISTAS EXPLODIDAS.....	14
DIAGRAMA ELÉTRICO.....	
PAINEL DE CIRCUITO IMPRESSO	

PRECAUÇÕES DE SEGURANÇA

ADVERTÊNCIA : Antes de reparar este chassis., leia as " PRECAUÇÕES DE RADIAÇÃO POR RAIOS X ", " INSTRUÇÕES DE SEGURANÇA " e " AVISO SOBRE SEGURANÇA DE PRODUTOS ".

INSTRUÇÕES DE SEGURANÇA

1. Quando o receptor está em operação, são geradas tensões potencialmente altas em torno de 25-29 kV. Operar o receptor fora de seu gabinete ou com a tampa traseira removida pode causar perigo de choque elétrico.
(1) Ninguém deverá tentar reparar o aparelho sem estar familiarizado com as precauções que são necessárias quando se trabalha com um equipamento de alta tensão.
(2) Sempre descarregue o anodo do cinescópio ao terra para evitar o risco de choque elétrico antes de remover o conector do anodo (chupeta de alta tensão).
(3) Descarregue completamente o potencial do cinescópio antes de manuseá-lo. O cinescópio é de alto vácuo, e se quebrar, os fragmentos de vidro são expelidos violentamente.
2. Se e queimar algum fusível deste receptor de televisão, substitua-o por outro especificado na lista de peças elétricas.
3. Quando substituir placas de circuito impresso ou módulos, fixe seus fios nos terminais antes de soldar.
4. Quando substituir uma resistência de potência (resistor de película de óxido metálico) no painel de circuito impresso, mantenha os seus terminais com 10mm de distância do painel.
5. Mantenha os fios e cabos distantes de componentes de alta potência e de alta temperatura.
6. Este receptor deve operar em redes de 100 a 240 V AC.
7. Antes de devolver este aparelho ao cliente, faça uma verificação de fuga de corrente sobre as partes metálicas expostas do gabinete, tais com antenas, terminais, cabeças de parafusos, tampas de metal, alavancas de controle, etc., e certifique-se de que o aparelho funciona sem perigo de choque elétrico. Ligue o cabo de rede do aparelho diretamente a uma tomada de força de 100-240 V AC. Não

utilize um transformador de isolamento durante este teste. Utilize um voltímetro de no mínimo 1KW por Volt de sensibilidade, da forma que se segue.

Quando a unidade estiver conectada ao AC, pulse o comutador primeiramente em "ON" (ligado) e em seguida em "OFF" (desligado), meça desde um ponto de terra conhecido (tal como um terminal de terra central da rede elétrica) a todas as partes metálicas expostas do televisor (antenas, teclas metálicas, capas metálicas, alavancas de controle, etc..) especialmente qualquer parte metálica que possa oferecer um caminho ao chassis. Nenhuma medição de corrente elétrica deve exceder 0,5 mA. Repita a prova mudando a posição do pluque de rede na tomada AC. Qualquer medição que não esteja dentro dos limites aqui especificados, representam risco potencial de choque elétrico que deve ser sanado antes que o aparelho retorne ao cliente.

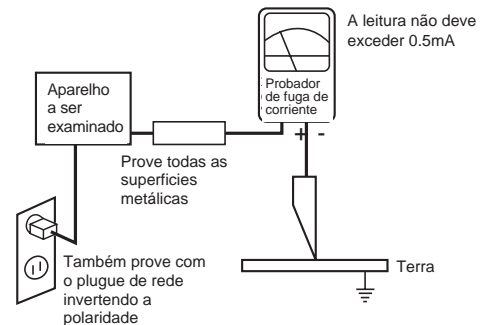

AVISO SOBRE SEGURANÇA DE PRODUTO

Muitas partes elétricas e mecânicas neste chassis, tem características relacionadas com a segurança. Estas características frequentemente não são verificadas nas inspeções visuais e a proteção que proporcionam contra a RADIAÇÃO DE RAIOS " X " nem sempre se obtém utilizando componente com maior potência ou de maior isolamento. As peças que têm essas características de segurança são identificadas por uma marca [Δ] impressa sobre o diagrama esquemático e a marca [] impressa na lista de partes elétricas. Antes de substituir algum destes componentes, leia cuidadosamente este manual. O uso de peças de reposição que não tenham as mesmas características de segurança, como especificado na lista de material de reposição, pode gerar Radiação de Raios "X".

INSTRUÇÕES DE REGULAÇÃO

1. Application Range

This spec. sheet is applied to all of the PP81A Chassis.

2. Specification

- (1) Because this is not a hot chassis, it is not necessary to use an isolation transformer. However, the use of isolation transformer will help protect test instrument.
- (2) Adjustment must be done in the correct order.
- (3) The adjustment must be performed in the circumstance of $25\pm 5^{\circ}\text{C}$ of temperature and $65\pm 10\%$ of relative humidity if there is no specific designation.
- (4) The input voltage of the receiver must keep 100~240V, 50/60Hz.
- (5) Before adjustment, execute Heat-Run for 30 minutes at RF no signal.

3. ADC calibration

	Component	RGB
MSPG-925FA	Model : 216 (720P@60Hz)	Model : 60 (1024X768@60Hz)

3-1. PC input ADC

(1) Auto RGB Gain/Offset Adjustment

- 1) Convert to PC in Input-source
- 2) Signal equipment displays
Output Voltage : 700 mVp-p
Impress Resolution XGA (1024 x 768 @ 60Hz)
Model : 60 in Pattern Generator
Pattern : 54 in Pattern Generator (MSPG-925 SERISE)
[1/2 Black & White Pattern (Refer below picture)].



<Fig. 1>

- 3) Adjust by commanding AUTO_COLOR_ADJUST(0xF1) 0x00 0x02 instruction.

(2) Confirmation

- 1) We confirm whether "0xB6(RGB)" address of EEPROM "0xA2" is "0xAA" or not.
- 2) If "0xB6(RGB)" address of EEPROM "0xB2" isn't "0xAA", we adjust once more
- 3) We can confirm the ADC values from "0xB0~0xB5(RGB)" addresses in a page "0xA2"

[Manual ADC process using Service Remocon. After enter Service Mode by pushing "ADJ" key, execute "ADC Adjust" by pushing "G" key at "Adjust-RGB".

3-2. COMPONENT input ADC

(1) Component Gain/Offset Adjustment

- 1) Convert to Component in Input-source
- 2) Signal equipment displays
Impress Resolution 720P
MODEL : 216 in Pattern Generator(720P Mode)
PATTERN : 33 in Pattern Generator(MSPG-925 SERISE)



Adjustment pattern (COMPONENT)

- 3) Adjust by commanding AUTO_COLOR_ADJUST(0xF1) 0x00 0x02 instruction

(2) Confirmation

- 1) We confirm whether "0xC8(720P)" address of EEPROM "0xA2" is "0xAA" or not.
- 2) If "0xC8(720P)" address of EEPROM "0xA2" isn't "0xAA", we adjust once more
- 3) We can confirm the ADC values from "0xB9~0xBE(480i)/0xC2~(1080i)" addresses in a page "0xA2"

4. PCB Assembly Adjustment Items

4-1. Option Adjustment Following BOM

Tool Option1
Tool Option2
Area Option

PP81A PDP P50WXGA	
Version	X.XX
USB	Version
X.XX	
UTT	XX
Tool Option1	3
Tool Option2	161
Area Option	16
:	

<Fig. 2>

- * Profile: Must be changed the option value because being different with some setting value depend on module, inch and market
- * Equipment : Adjustment Remote Controller

- (1) Push the IN-START key in the Adjust R/C.
- (2) Input the Option Number that was specified in the BOM, into the Shipping area.
- (3) Select "Tool Option1/ Tool Option2/ Area Option" by using D/E (CH+/-) key, and press the number key(0~9) consecutively
ex) If the value of Tool Option1 is 7, input the data using number key "7" (Fig. 2)

Caution: Don't Push "IN-STOP" key after PCB assembly adjustment.

- (4) Adjustment method
Before PCBA check, have to change the Tool option and Area option

[About PDP

After done all adjustments, Press IN-START button and compare Tool option and Area option value with its BOM, if it is correctly same then Change "RF mode" and then unplug the AC cable.

If it is not same, then correct it same with BOM and unplug AC cable.

For correct it to the model's module from factory JIG model.

- [Don't push The IN-STOP KEY after completing the function inspection.

5. S/W Program Download

5-1. Profile

This is for downloading the s/w to the flash memory of the IC803

5-2. Equipment

- (1) PC
- (2) ISP_tool program
- (3) Download jig

5-3. Connection Structure



5-4. Connection Condition

- (1) IC name and circuit number : Flash Memory and IC803
- (2) Use voltage : 3.3V (5 pin)
- (3) SCL : 15 pin
- (4) SDA : 12 pin
- (5) Tact time : about 2min and 30seconds

6. Download Method (PCB Ass'y)

6-1. Preliminary Steps



- (1) Connect the download jig to D-sub jack



- (2) Connect the PC to USB jack

<HDMI 1 : 256bytes>

Addr	00	01	02	03	04	05	06	07	08	09	0A	0B	0C	0D	0E	0F	
0000	00	FF	FF	FF	FF	FF	FF	00	1E	6D	⊕		⊕				
0010	⊕		01	03	08	46	27	78	EA	D9	B0	A3	57	49	9C	25	
0020	11	49	4B	A1	08	00	01	01	45	40	61	40	01	01	01	01	
0030	01	01	01	01	01	01	1										
0040	1					2											
0050	2										00	00	00	FD	00	3B	
0060	46	1F	4A	10	00	0A	20	20	20	20	20	20	⊕				
0070	⊕														01	⊕	
0080	02	03	26	F1	50	02	03	84	05	07	10	11	12	13	14	16	
0090	1F	20	21	22	01	23	09	07	07	83	01	00	00	68	03	0C	
00A0	00	10	00	B8	2D	00	01	1D	00	80	51	D0	1C	20	40	80	
00B0	35	00	BC	88	21	00	00	1E	8C	0A	D0	8A	20	E0	2D	10	
00C0	10	3E	96	00	13	8E	21	00	00	18	00	00	00	00	00	00	
00D0	00	00	00	00	00	00	00	00	00	00	00	00	01	1D	80	18	
00E0	71	1C	16	20	58	2C	25	00	C4	8E	21	00	00	9E	00	00	
00F0	00	00	00	00	00	00	00	00	00	00	00	00	00	00	00	⊕	

<HDMI 2 : 256bytes>

Addr	00	01	02	03	04	05	06	07	08	09	0A	0B	0C	0D	0E	0F	
0000	00	FF	FF	FF	FF	FF	FF	00	1E	6D	⊕		⊕				
0010	⊕		01	03	08	46	27	78	EA	D9	B0	A3	57	49	9C	25	
0020	11	49	4B	A1	08	00	01	01	45	40	61	40	01	01	01	01	
0030	01	01	01	01	01	01	1										
0040	1					2											
0050	2										00	00	00	FD	00	3B	
0060	46	1F	4A	10	00	0A	20	20	20	20	20	20	⊕				
0070	⊕														01	⊕	
0080	02	03	26	F1	50	02	03	84	05	07	10	11	12	13	14	16	
0090	1F	20	21	22	01	23	09	07	07	83	01	00	00	68	03	0C	
00A0	00	20	00	B8	2D	00	01	1D	00	80	51	D0	1C	20	40	80	
00B0	35	00	BC	88	21	00	00	1E	8C	0A	D0	8A	20	E0	2D	10	
00C0	10	3E	96	00	13	8E	21	00	00	18	00	00	00	00	00	00	
00D0	00	00	00	00	00	00	00	00	00	00	00	00	01	1D	80	18	
00E0	71	1C	16	20	58	2C	25	00	C4	8E	21	00	00	9E	00	00	
00F0	00	00	00	00	00	00	00	00	00	00	00	00	00	00	00	⊕	

<HDMI 3 : 256bytes>

Addr	00	01	02	03	04	05	06	07	08	09	0A	0B	0C	0D	0E	0F	
0000	00	FF	FF	FF	FF	FF	FF	00	1E	6D	⊕		⊕				
0010	⊕		01	03	08	46	27	78	EA	D9	B0	A3	57	49	9C	25	
0020	11	49	4B	A1	08	00	01	01	45	40	61	40	01	01	01	01	
0030	01	01	01	01	01	01	1										
0040	1					2											
0050	2										00	00	00	FD	00	3B	
0060	46	1F	4A	10	00	0A	20	20	20	20	20	20	⊕				
0070	⊕														01	⊕	
0080	02	03	26	F1	50	02	03	84	05	07	10	11	12	13	14	16	
0090	1F	20	21	22	01	23	09	07	07	83	01	00	00	68	03	0C	
00A0	00	30	00	B8	2D	00	01	1D	00	80	51	D0	1C	20	40	80	
00B0	35	00	BC	88	21	00	00	1E	8C	0A	D0	8A	20	E0	2D	10	
00C0	10	3E	96	00	13	8E	21	00	00	18	00	00	00	00	00	00	
00D0	00	00	00	00	00	00	00	00	00	00	00	00	01	1D	80	18	
00E0	71	1C	16	20	58	2C	25	00	C4	8E	21	00	00	9E	00	00	
00F0	00	00	00	00	00	00	00	00	00	00	00	00	00	00	00	⊕	

o Detail EDID Options are below (, , , ,)

Product ID

Model Name	Product ID		
	DEC	HEX	EDID table
50PG60UR-TA	50077(A)	C39D	9DC3
	50078(D)	C39E	9EC3
50PG20R-MA	50079(A)	C39F	9FCE
	50080(D)	C3A0	A0C3
42PG20R-MA	40197(A)	9005	059D
	40198(D)	9006	069D
42PG10R-TA	40225(A)	9021	219D
	40226(D)	9022	229D
42PG200R-ZA	40225(A)	9021	219D
	40226(D)	9022	229D

Serial No

=> Controlled on production line

Month, Year

=> Controlled on production line:

- ex) Monthly: '11' -> '0B'
- Year: '2007' -> '11'

Model Name(Hex)

MODEL NAME	Model Name(HEX)															
LG TV	00	00	00	FC	00	4C	47	20	54	56	0A	20	20	20	20	20

Checksum

=> Changeable by total EDID data

1) 42inch Model

	(HEX)																	
50/60inch Model	1B	21	50	A0	51	00	1E	30	48	88	35	00	BC	88	21	00	00	1C
42inch Model	64	19	00	40	41	00	26	30	18	88	38	00	BC	88	21	00	00	00

2) 50/60inch Model

	(HEX)																	
50/60inch Model	0E	1F	00	80	51	00	1E	30	40	80	37	00	BC	88	21	00	00	18
42inch Model	A0	0F	20	00	31	58	1C	20	28	80	11	00	BC	38	20	00	00	00

7-5. Preparation for Adjustment

- (1) As above Fig. 3, Connect the Set, EDID Download Jig., PC & Cable
- (2) Turn on the PC & EDID Download Jig. And Execute the S/W : EDID TESTER Ver.2.5
- (3) Set up the S/W option
Repeat Number : 5
Device Address : A0
PageByte : 8

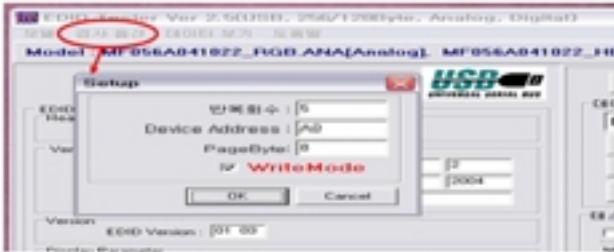

(4) Power on the Set

1) Sequence of Adjustment

1. DDC data of Analog-RGB

(1) Init the data



(2) Load the EDID data.(Open File).

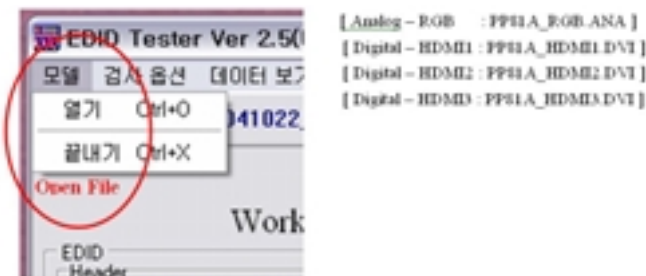

(3) Set the S/W as below.

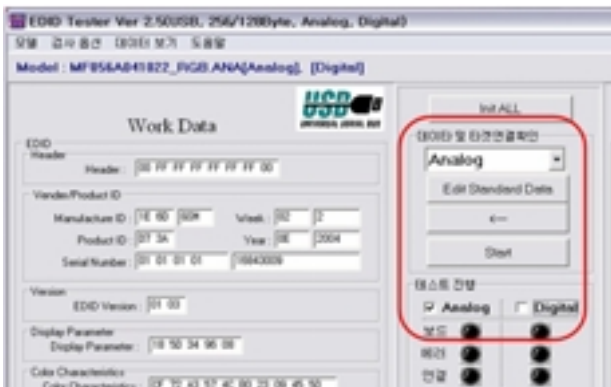

(4) Push the "Write Data & Verify" button. And confirm "Yes".

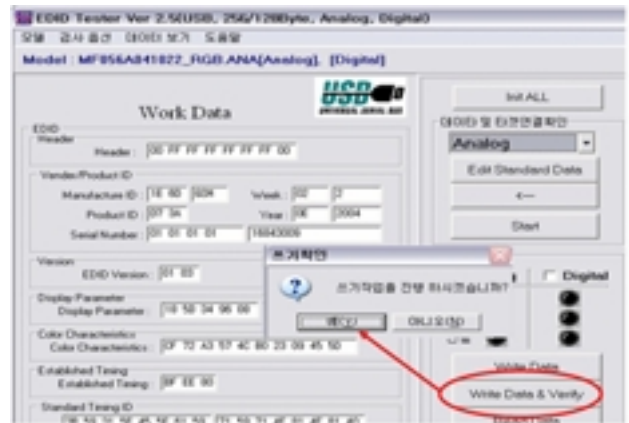

(5) If the writing is finished, you will see the "OK" message.



8. HDCP (High-Bandwidth Digital Contents Protection)

- (1) Connect D-sub Signal Cable to D-Sub Jack
- (2) Input HDCP key with HDCP-key- in-program
- (3) HDCP Key value is stored on Main M-STAR IC(LGE6891DD) which is 0x80~0x90 addresses of 0x00~0x01 page(EEPROM MAP PAGE0~PAGE1 / START :A080)
- (4) Play the Equipment(DVD Player) included HDCP Key and confirm whether picture is displayed or not of using DVD Player.
- (5) HDCP Key value is different among the sets

9. Adjustment of White Balance

9-1. Purpose and Principle for Adjustment of the Color Temperature

- (1) Purpose: Adjust the color temperature to reduce the deviation of the module color temperature.
- (2) Principle : To adjust the white balance without the saturation, Fix the one of R/G/B gain to C0 and decrease the others.
- (3) Adjustment mode: Two modes of Cool and Warm (Cool data is automatically calibrated by the Medium data)

9-2. Required Equipment

- (1) Remote controller for adjustment
 - (2) Color Analyzer : CA-100+ or CA-210 or same product
- PLASMA TV(ch : 10)
 - (3) Auto W/B adjustment instrument(only for Auto adjustment)
- Do the white balance adjustment under the 10LUX
- [Notice: When using the Color Analyzer with PDP, recommend the CA-100 more than CA-210.
If CA-100 can not available, it is also good to use the CA-210.
- (4) PC (for communication through RGB)
 - (5) Pattern Generator (MSPG-925FA etc.)
-Before white balance, press the ADJ key 2times and do the reset like Fig. 4
-To enter White-balance mode, press the ADJ key 2times.

[Caution: System control Host should be "DDC" for adjustment.



<Fig. 4>

9-3. Connecting Diagram of Equipment for Measuring (For Automatic Adjustment)

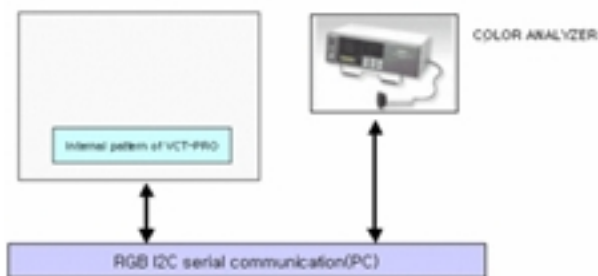

- (1) Enter the adjustment mode of the white balance
 - Enter the white balance adjustment mode at the same time heat-run mode when pushing the power on by power only key
 - Maintain the white balance adjustment mode with same condition of Heat-run
 - Maintain after AC off/on in status of Heat-run pattern display
 - (2) Release the white balance adjustment mode
 - Release the adjust mode after AC off/on or std-by off/on in status of finishing the Hear-run mode
 - Release the Adjust mode when receiving the aging off command(F3 00 00) from adjustment equipment)
 - (3) Enter the adjust mode of white balance
 - Enter the white balance adjustment mode with aging command(F3, 00, FF)
- o Color Temperature & Color Coordinates Setting
 - When adjusting the Color Temperature, Color Analyzer CA-210(Matrix should be corrected through CH10 of CS-1000) should be used. When CA-210 have used, it don't need to fit the CH10.
 - Adjust the Color Temperature based below adjustment color coordinates.
 - o Target Value CA-210(LCD : CH 9, PDP : CH10), CA-100(PDP) (Standard color coordinate and temperature when using the CA-100+ or CA210 equipment)

Mode	Color coordinate		Temp	Δuv
	X	Y		
Medium	0.285±0.002	0.293±0.002	9,300k	+0.000
Warm	0.313±0.002	0.329±0.002	6,500k	+0.003

- o Synchronization relation between PSM and CSM

PSM	CSM
Vivid	Cool
Mild	Warm

o DDC Adjustment Command Set

No.	Adjustment content	CMD(HEX)	ADR	VALUE	detail
1	Aging On/Off	F3	00	FF/00	00 : OFF 01 : ON FF : WB Ready
2	Input select	F4	00		0x10 : TV 0x20 : AV1 0x21 : AV2 0x23 : AV3 0x40 : Component1 0x41 : Component2 0x60 : RGB PC 0x90 : HDMI1 0x91 : HDMI2 0x92 : HDMI3
3	R GAIN	16	00	00 - FE	Gain Adjustment
4	G GAIN	18		00 - FE	CSM COOL
5	B GAIN	1A		00 - FE	
6	R GAIN	16	01	00 - FE	Gain Adjustment
	G GAIN	18		00 - FE	CSM MEDIUM
	B GAIN	1A		00 - FE	
	R GAIN	16	02	00 - FE	Gain Adjustment
	G GAIN	18		00 - FE	CSM WARM
	B GAIN	1A		00 - FE	
	CSM mode	F2	00	00	COOL
				01	MEDIUM
				02	WARM
	EEPROM Read	E7	00	00	EEPROM read
	EEPROM Write	E8	00	data	EEPROM write

[R/G/B GAIN max value : C0

9-4. Adjustment of White Balance for Manual Adjustment

Adjustment mode: Two modes of Medium(Vivid) and Warm (Cool data is automatically calibrated by the Medium data)

- Equipment : 1) Color analyzer(CA100+, CA210) should be used in the calibrated ch by CS-1000.(LCD : CH9, PDP : CH10)
- 2) Adjustment remocon

- For manual adjustment, it is also possible by the following sequence.

Operate the zero-calibration of the CA-100+ or CA-210, then stick sensor to the module when adjusting.

- (1) Select white pattern of heat-run by pressing "POWER ON" key on remote control for adjustment then operate heat run longer than 15 minutes. (recommend)
(If not executed this step, the condition for W/B will be different)
- (2) Changing to the AV mode by remote control.(Push front-AV)
- (3) Input external pattern(85% white pattern).
- (4) Stick sensor to center of the screen and select each items (Red/Green/Blue Gain and Offset) using D/E (CH +/-) key on R/C..
- (5) Adjust R/ G/B Gain using F/G(VOL +/-) key on R/C.
- (6) Adjust two modes of Medium(Vivid) and Warm as below figure.
(Fix the one of R/G/B and change the others)

- 1) Default : Medium(Vivid)
- 2) Push the "VOL +" key twice : Warm

Mode	Color coordinate		Temp	Δ_{uv}
	X	Y		
Medium	0.285±0.002	0.293±0.002	9,300k	+0.000
Warm	0.313±0.002	0.329±0.002	6,500k	+0.003

[Refer to the below case to know what value is fixed.

[CASE]

First adjust the coordinate much away from the target value(x, y).

1. $x, y > \text{target}$
 - 1) Decrease the R, G.
 2. $x, y < \text{target}$
 - 1) First decrease the B gain,
 - 2) Decrease the one of the others.
 - In case of decreasing the x, decreasing the R : fix G
 - In case of decreasing the y , decreasing the G : fix R
 3. $x > \text{target} , y < \text{target}$
 - 1) First decrease B, so make y a little more than the target.
 - 2) Adjust x value by decreasing the R
 4. $x < \text{target} , y > \text{target}$
 - 1) First decrease B, so make x a little more than the target.
 - 2) Adjust x value by decreasing the G
- (7) When adjustment is completed, Exit adjustment mode using EXIT key on R/C.

Caution: Each PCB assembly must be checked by check JIG set. (Because power PCB Assembly damages to PDP Module, especially be careful)

10. POWER PCB Assy Voltage Adjustment(Va, Vs voltage Adjustment)

10-1. Test Equipment: D.M.M 1EA

10-2. Connection Diagram for Measuring

Refer to Fig. 5

10-3. Adjustment Method

(1) Va Adjustment

- 1) After receiving 100% Full White Pattern, HEAT RUN.
- 2) Connect + terminal of D. M..M. to Va pin of P812, connect -terminal to GND pin of P812.
- 3) After turning VR901,voltage of D.M.M adjustment as same as Va voltage which on label of panel right/top (deviation; ±0.5V)

(2) Vs Adjustment

- 1) Connect + terminal of D. M..M. to Vs pin of P812, connect -terminal to GND pin of P812.
- 2) After turning VR951 401, voltage of D.M.M adjustment as same as Vs voltage which on label of panel right/top (deviation ; ±0.5V)

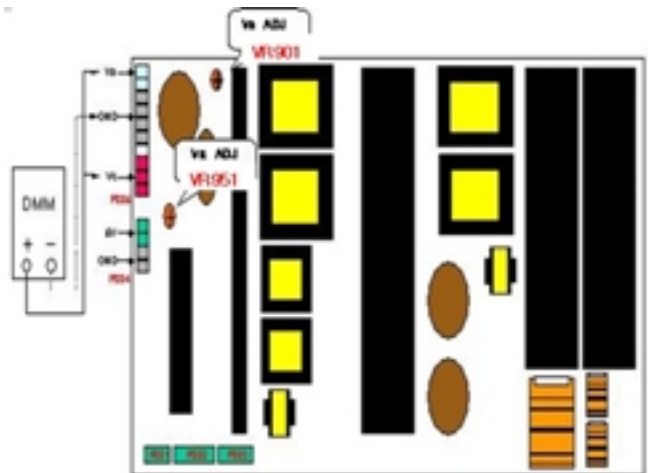

<Fig. 7> Connection Diagram of Power Adjustment for Measuring

DIAGRAMA DE BLOCOS

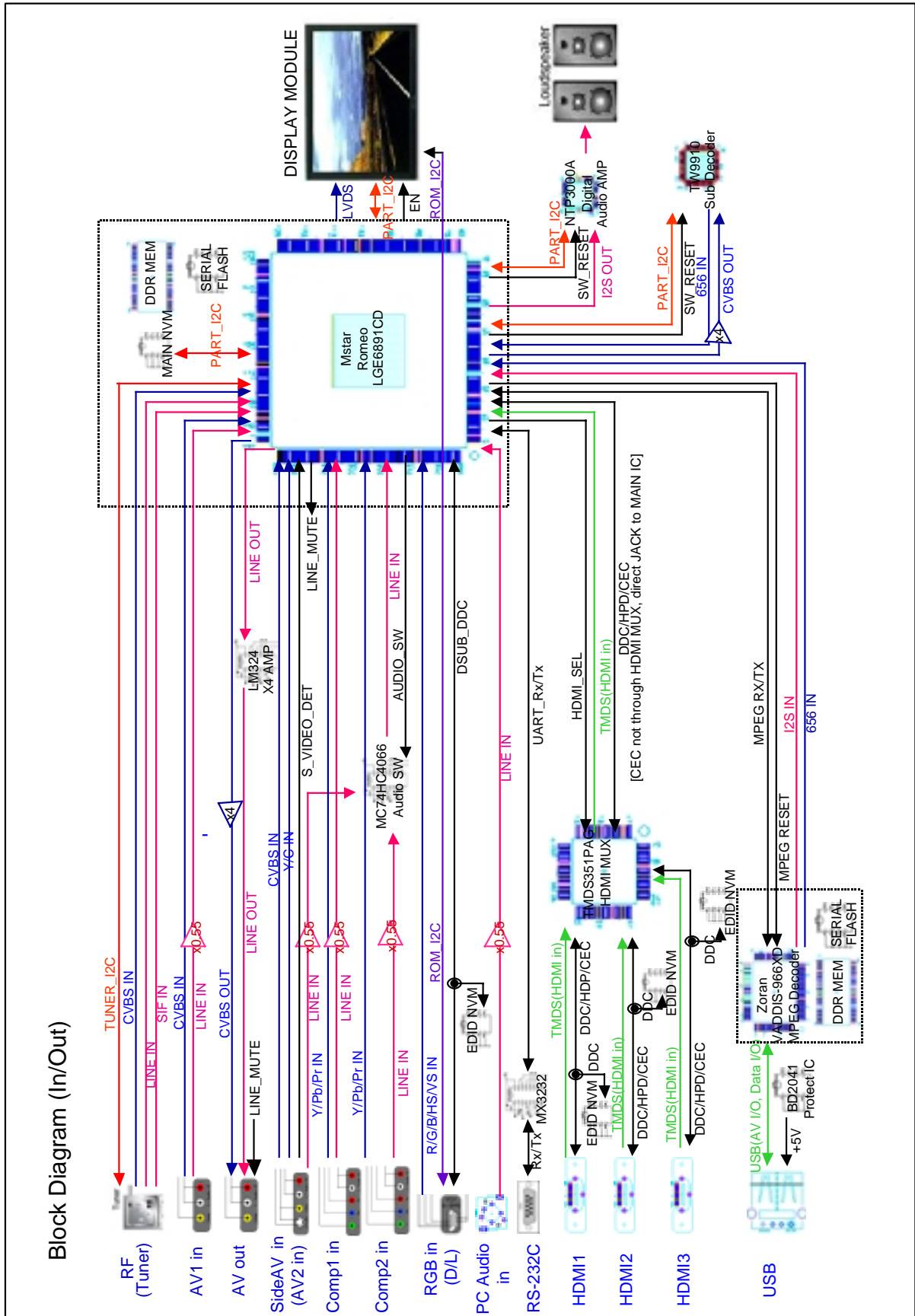

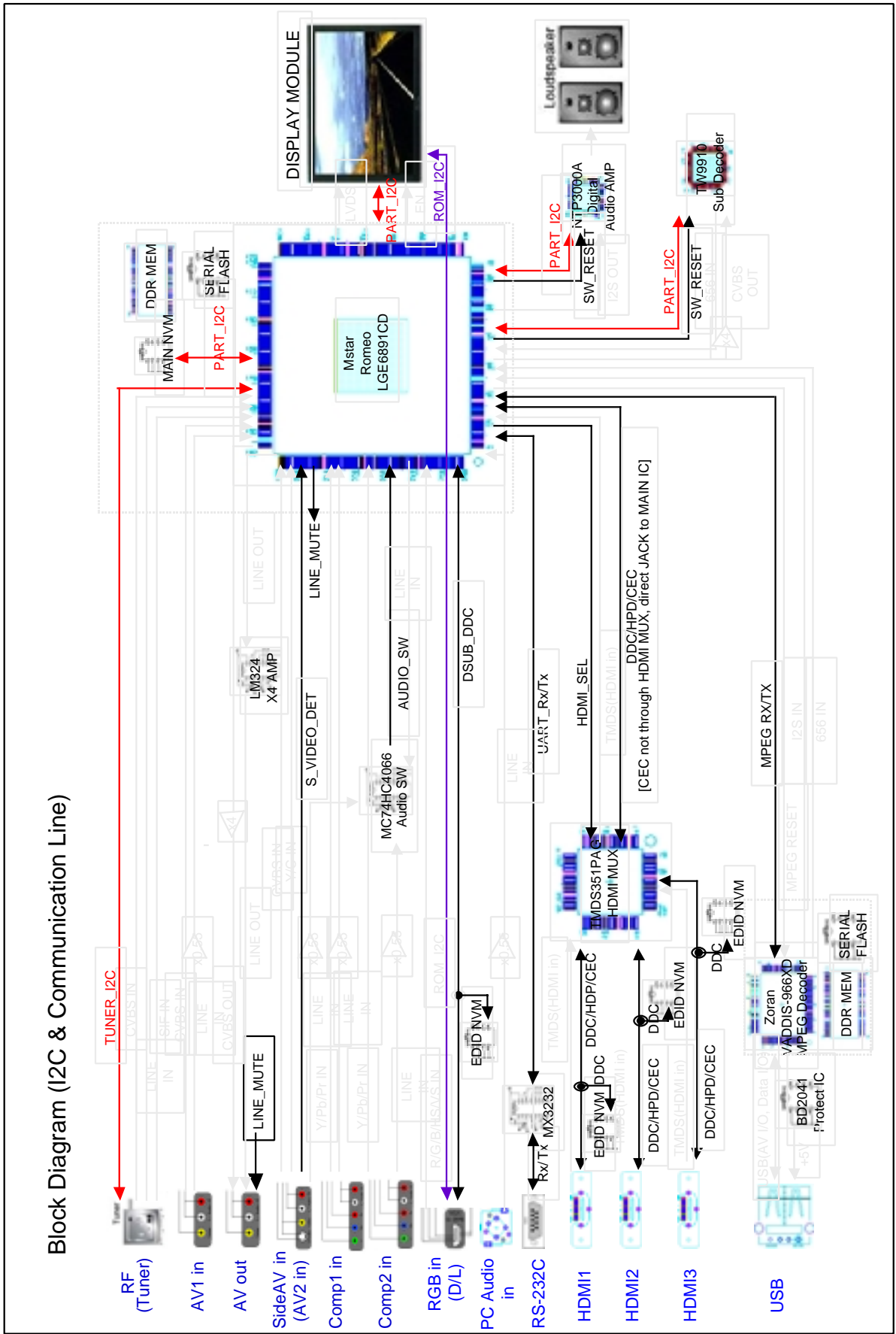

VISTAS EXPLODIDAS

IMPORTANT SAFETY NOTICE

Many electrical and mechanical parts in this chassis have special safety-related characteristics. These parts are identified by  in the Schematic Diagram and EXPLODED VIEW. It is essential that these special safety parts should be replaced with the same components as recommended in this manual to prevent X-RADIATION, Shock, Fire, or other Hazards. Do not modify the original design without permission of manufacturer.

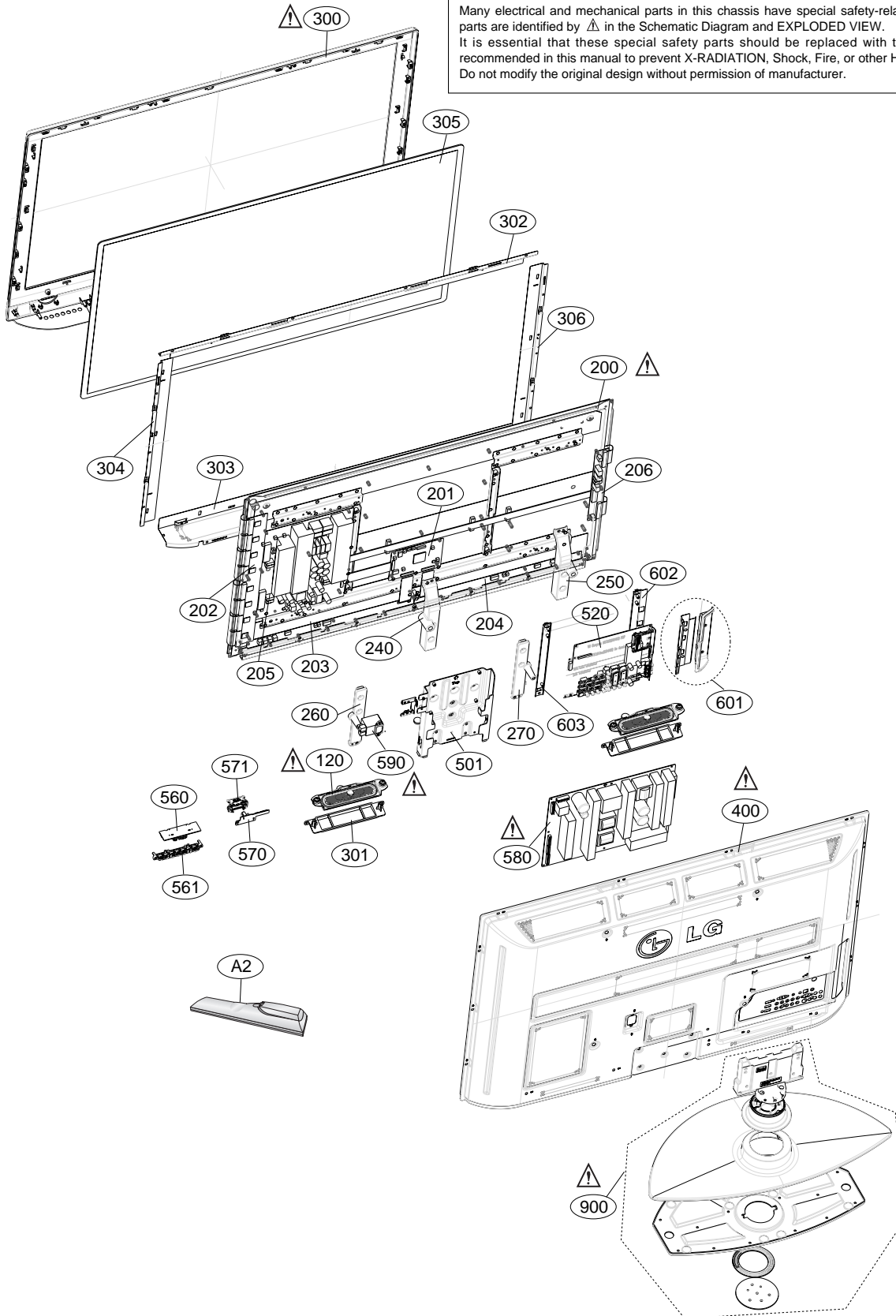

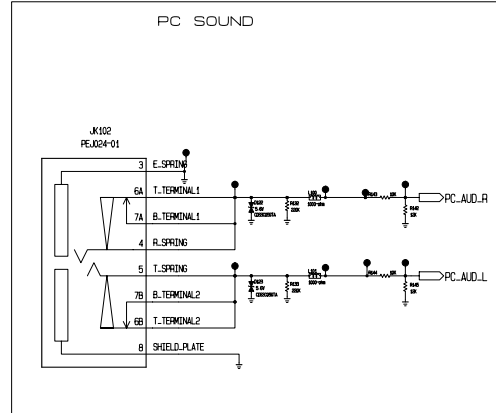
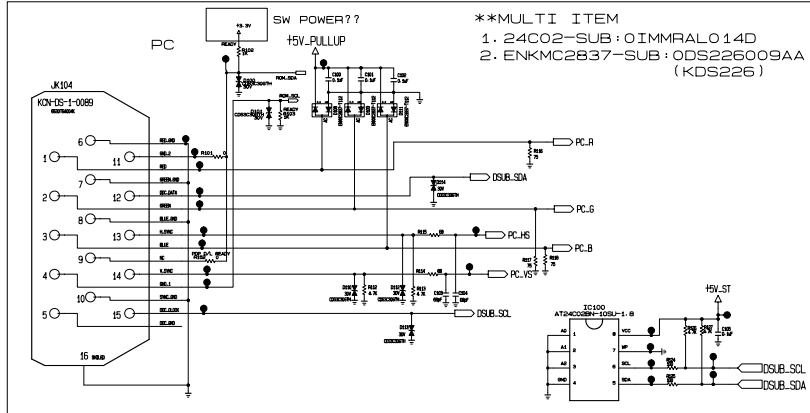
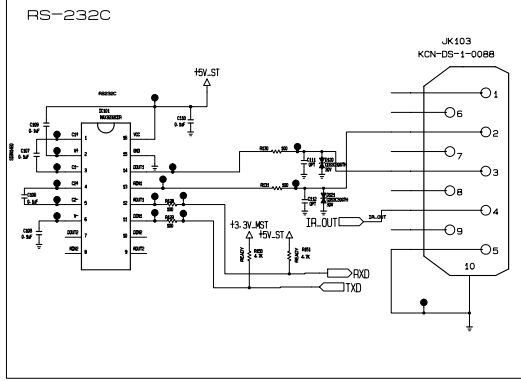
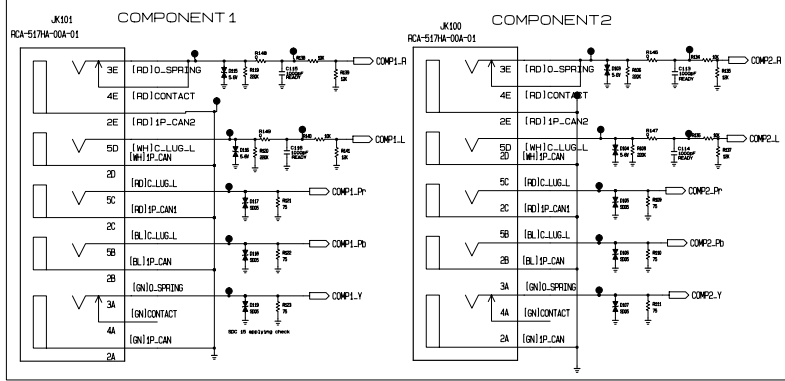

THE Δ SYMBOL MARK OF THIS SCHEMATIC DIAGRAM INCORPORATES SPECIAL FEATURES IMPORTANT FOR PROTECTION FROM X-RADIATION, FILM AND ELECTRICAL SHOCK HAZARDS. WHEN SERVICING IT IS ESSENTIAL THAT ONLY MANUFACTURERS SPECIFIED PARTS BE USED FOR THE CRITICAL COMPONENTS IN THE Δ SYMBOL MARK OF THE SCHEMATIC.

INPUT 1 : COMP1/2, RS232C, PC
MSTAR N-EU 2007/10/29
INPUT1 1/10

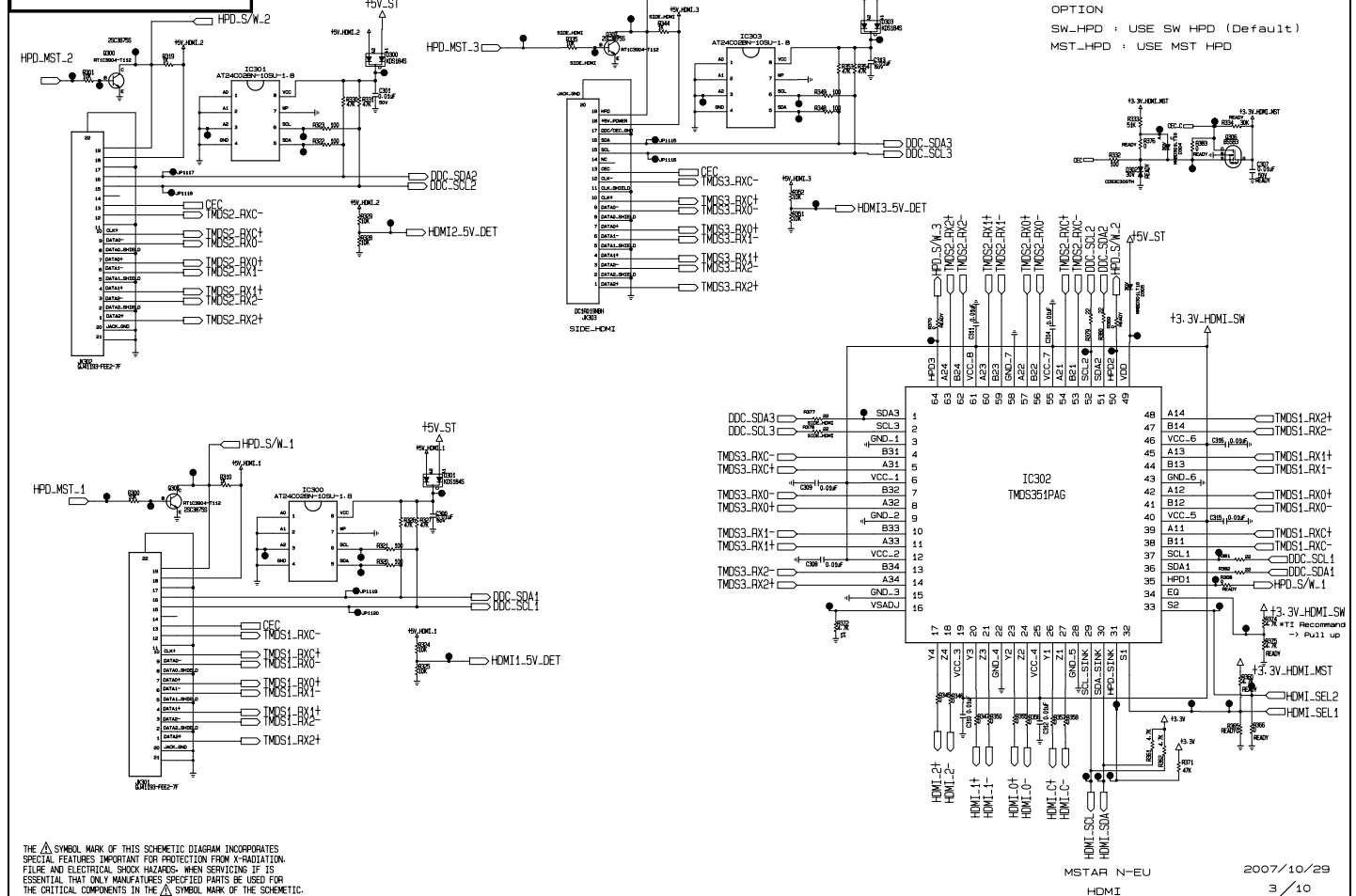

THE Δ SYMBOL MARK OF THIS SCHEMATIC DIAGRAM INCORPORATES SPECIAL FEATURES IMPORTANT FOR PROTECTION FROM X-RADIATION, FILM AND ELECTRICAL SHOCK HAZARDS. WHEN SERVICING IT IS ESSENTIAL THAT ONLY MANUFACTURERS SPECIFIED PARTS BE USED FOR THE CRITICAL COMPONENTS IN THE Δ SYMBOL MARK OF THE SCHEMATIC.

MSTAR N-EU 2007/10/29
HDMI 3/10

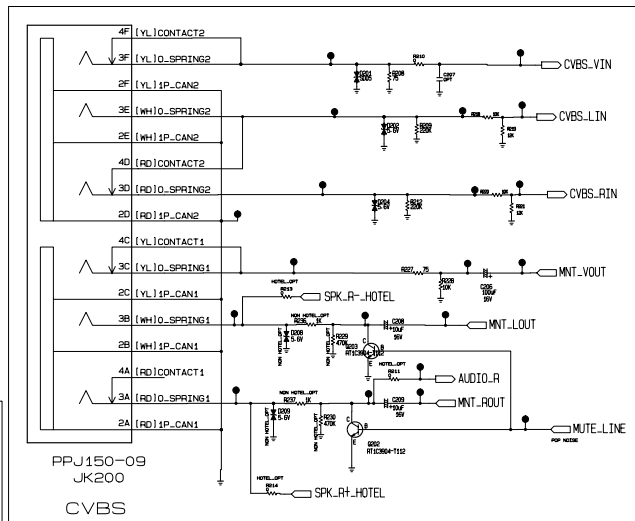
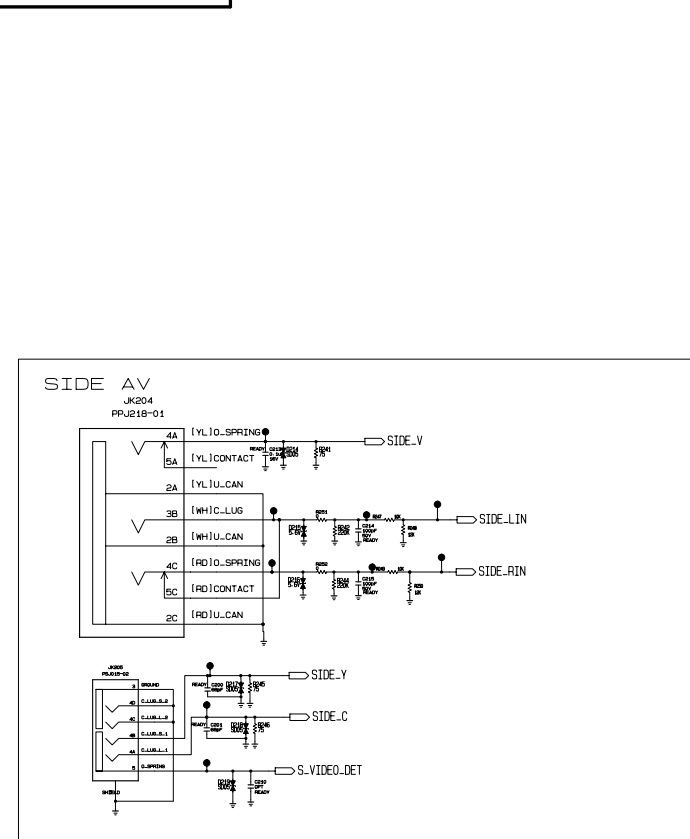

THE Δ SYMBOL MARK OF THIS SCHEMATIC DIAGRAM INCORPORATES SPECIAL FEATURES IMPORTANT FOR PROTECTION FROM X-RADIATION, FILM AND ELECTRICAL SHOCK HAZARDS. WHEN SERVICING IT IS ESSENTIAL THAT ONLY MANUFACTURERS SPECIFIED PARTS BE USED FOR THE CRITICAL COMPONENTS IN THE Δ SYMBOL MARK OF THE SCHEMATIC.

INPUT 2 : CVBS, SIDE AV
MSTAR N-EU 2007/10/29
INPUT2 2/10

PANEL WAFER

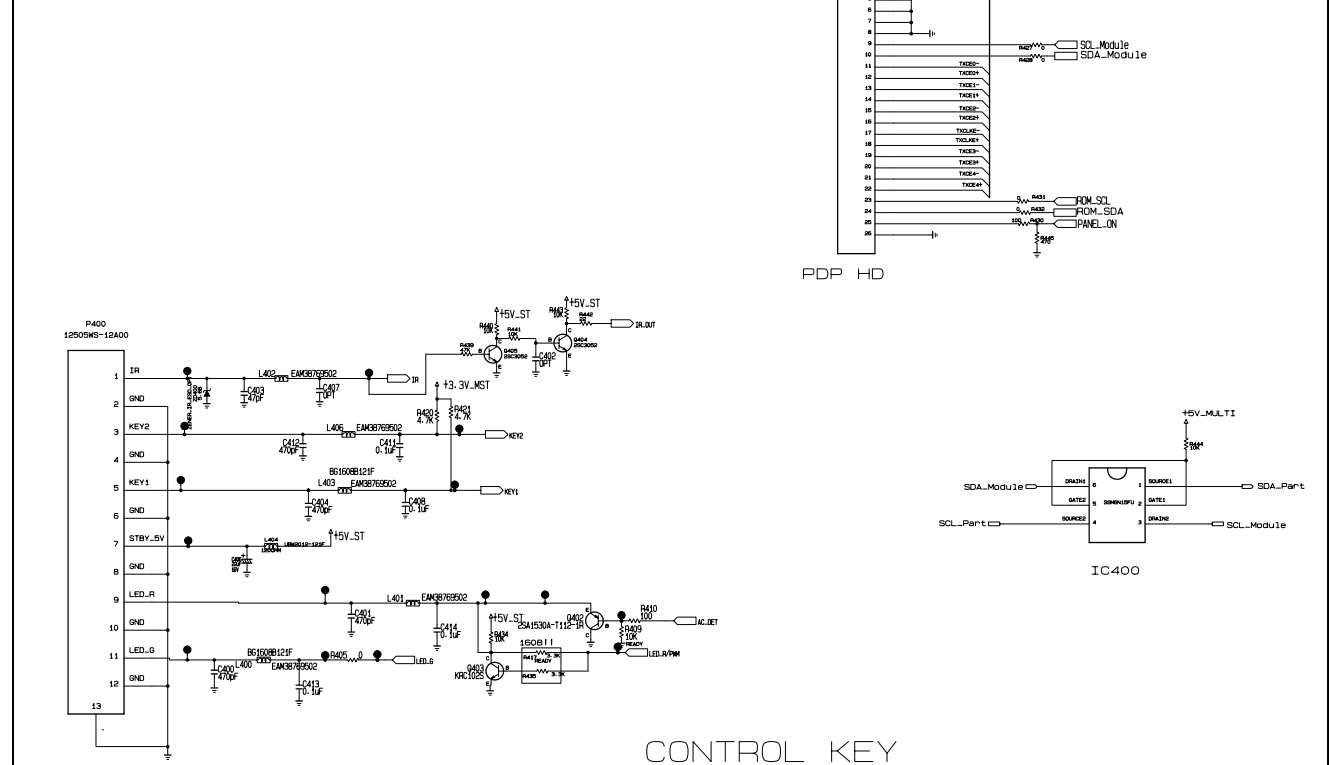

THE Δ SYMBOL MARK OF THIS SCHEMATIC DIAGRAM INCORPORATES SPECIAL FEATURES IMPORTANT FOR PROTECTION FROM X-RADIATION, FILM AND ELECTRICAL SHOCK HAZARDS. WHEN SERVICING IT IS ESSENTIAL THAT ONLY MANUFACTURERS SPECIFIED PARTS BE USED FOR THE CRITICAL COMPONENTS IN THE Δ SYMBOL MARK OF THE SCHEMATIC.

MSTAR 2007/10/29
LVDS_CTR KEY 4/10

EAX43012502
MSTAR PDP NONEU

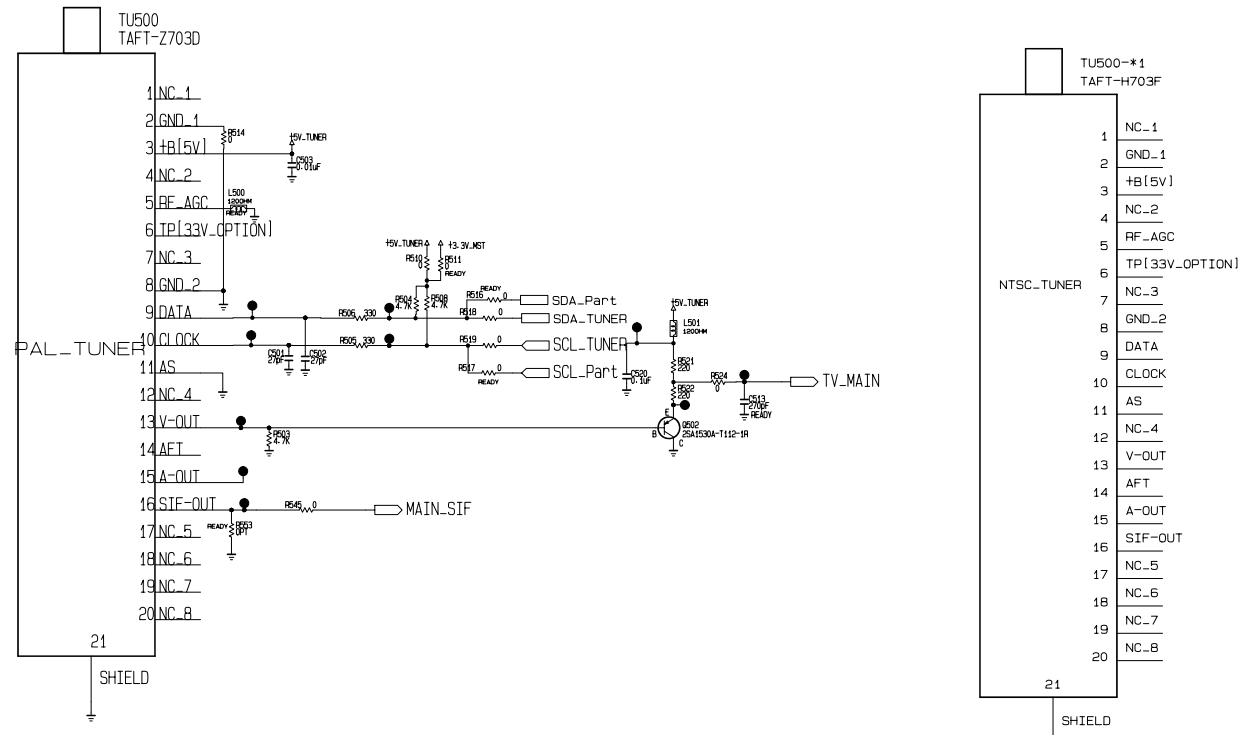

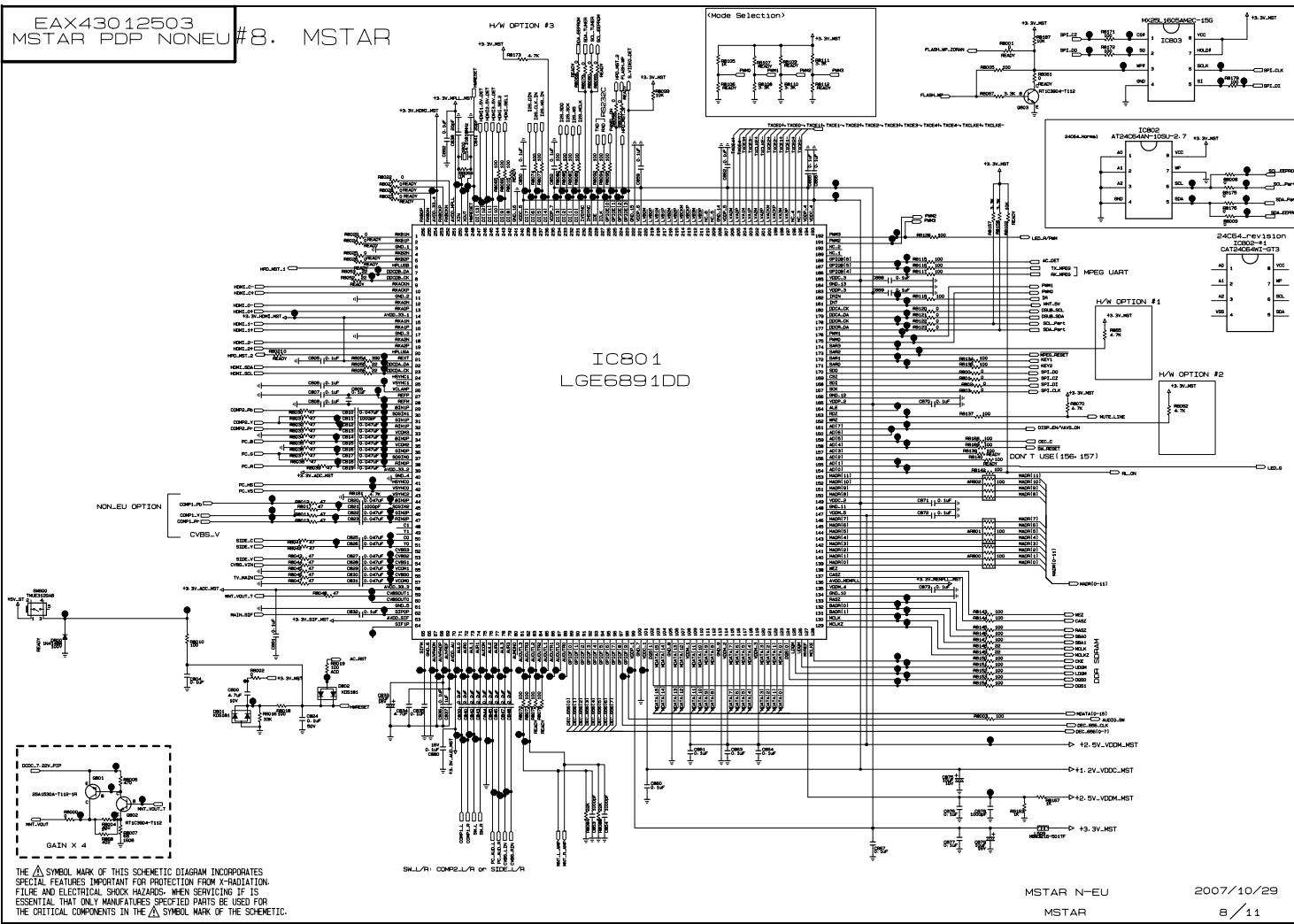

THE Δ SYMBOL MARK OF THIS SCHEMATIC DIAGRAM INCORPORATES SPECIAL FEATURES IMPORTANT FOR PROTECTION FROM X-RADIATION. FILM AND ELECTRICAL SHOCK HAZARDS. WHEN SERVICING IF IS ESSENTIAL THAT ONLY MANUFACTURER SPECIFIED PARTS BE USED FOR THE CRITICAL COMPONENTS IN THE Δ SYMBOL MARK OF THE SCHEMATIC.

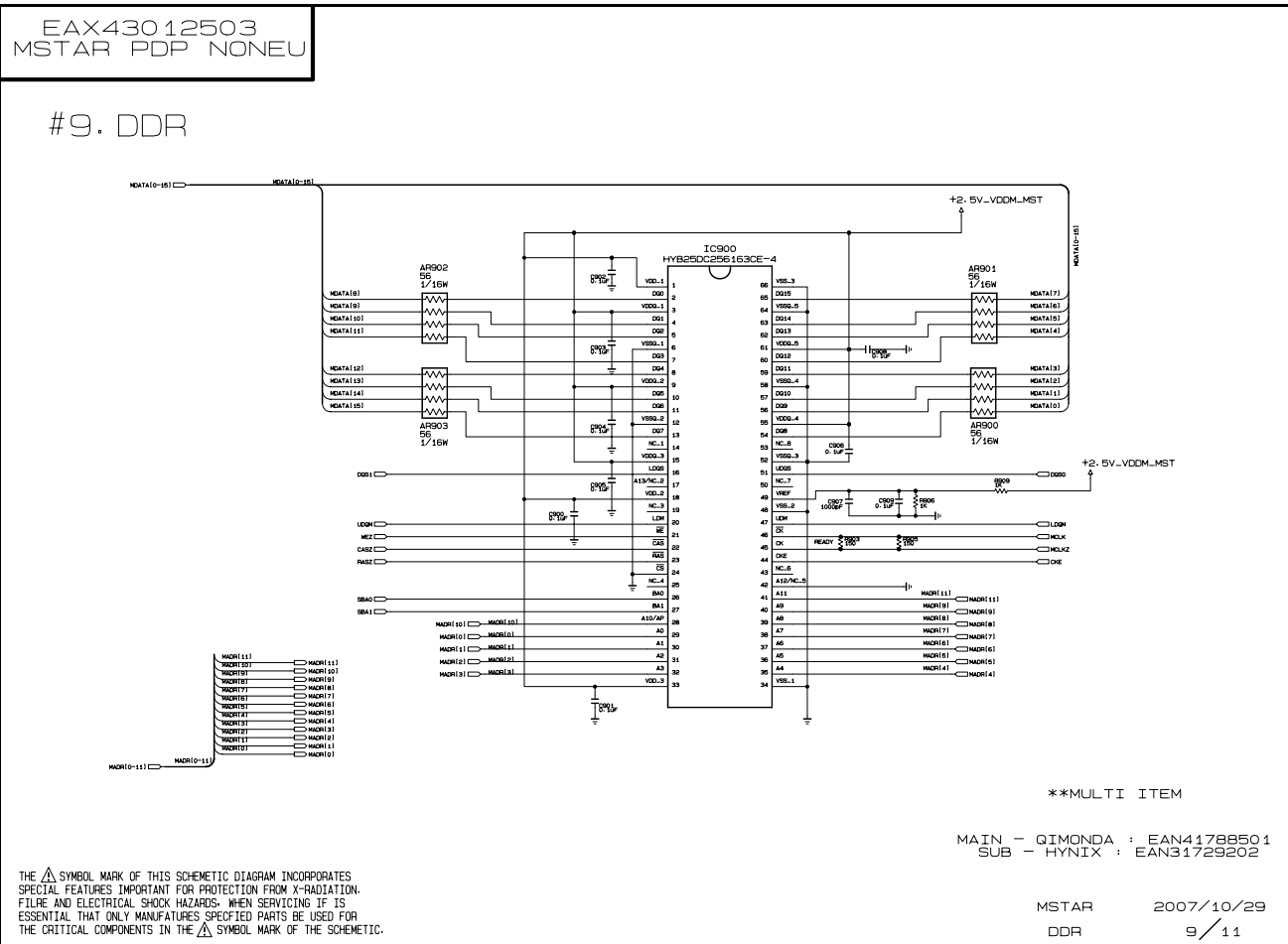

THE Δ SYMBOL MARK OF THIS SCHEMATIC DIAGRAM INCORPORATES SPECIAL FEATURES IMPORTANT FOR PROTECTION FROM X-RADIATION. FILM AND ELECTRICAL SHOCK HAZARDS. WHEN SERVICING IF IS ESSENTIAL THAT ONLY MANUFACTURER SPECIFIED PARTS BE USED FOR THE CRITICAL COMPONENTS IN THE Δ SYMBOL MARK OF THE SCHEMATIC.

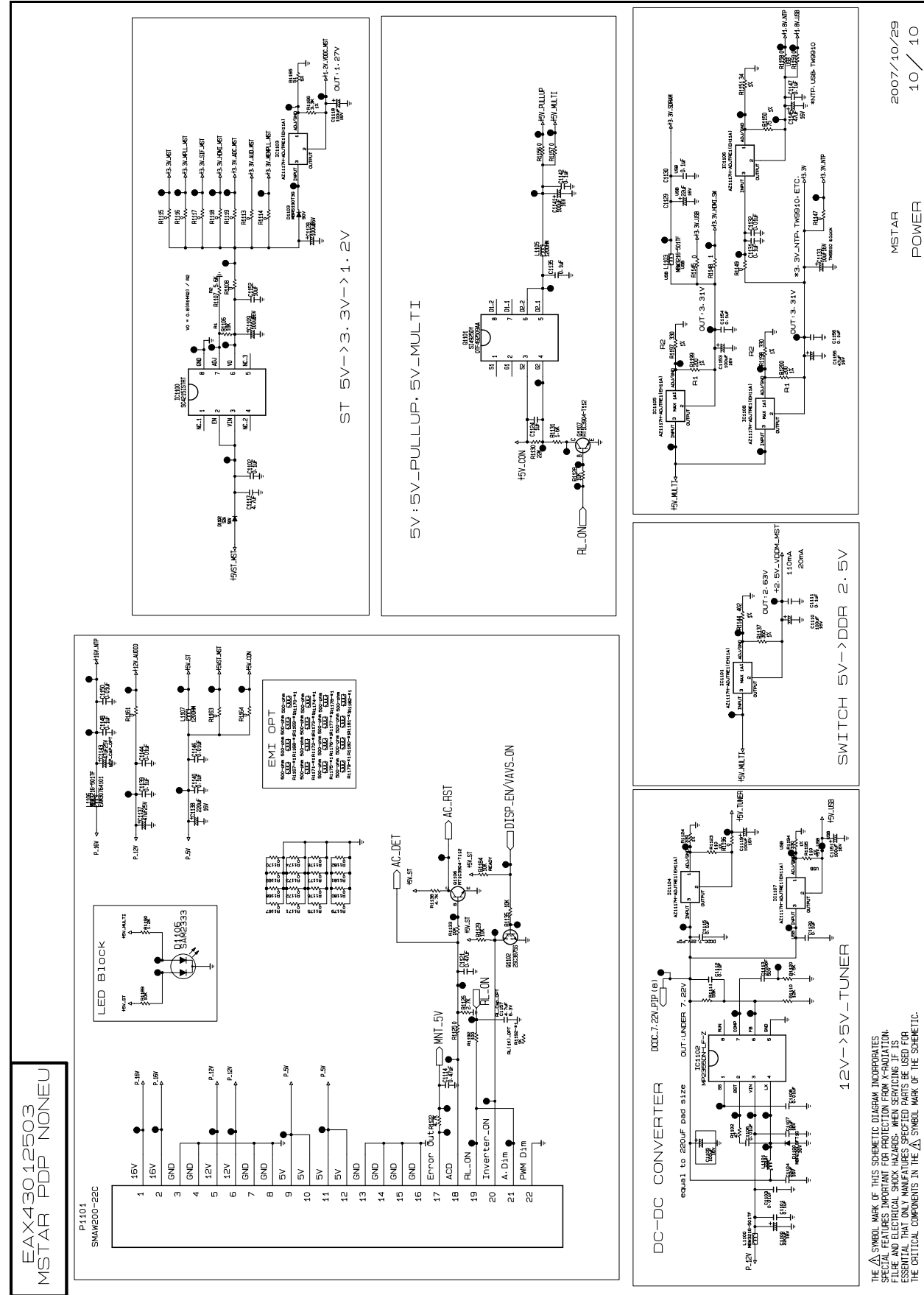

THE Δ SYMBOL MARK OF THIS SCHEMATIC DIAGRAM INCORPORATES SPECIAL FEATURES IMPORTANT FOR PROTECTION FROM X-RADIATION. FILM AND ELECTRICAL SHOCK HAZARDS. WHEN SERVICING IF IS ESSENTIAL THAT ONLY MANUFACTURER SPECIFIED PARTS BE USED FOR THE CRITICAL COMPONENTS IN THE Δ SYMBOL MARK OF THE SCHEMATIC.

MAIN(TOP)

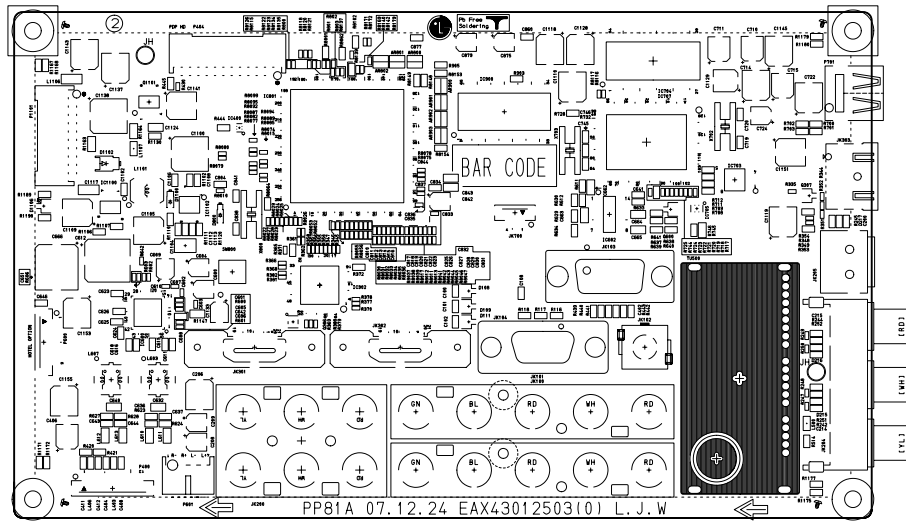

MAIN(BOTTOM)

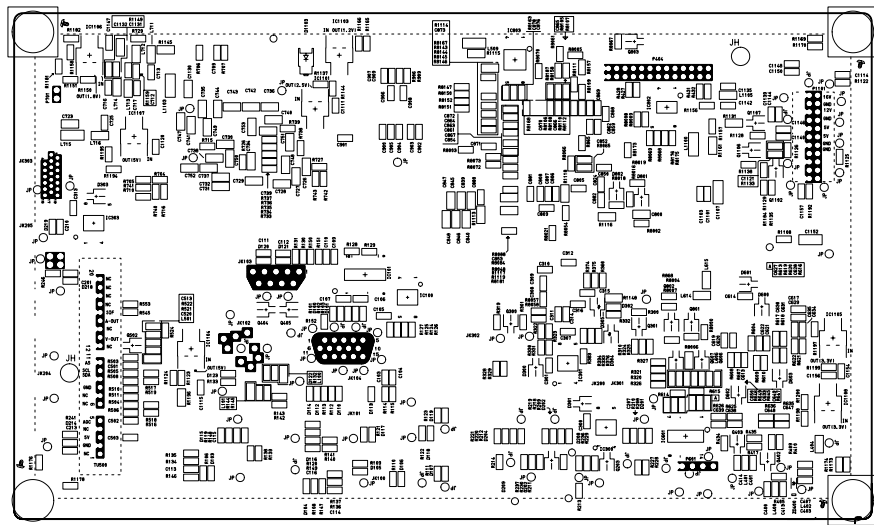

CONTROL(TOP)

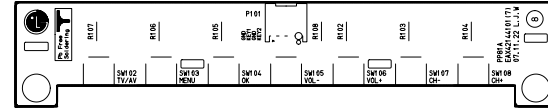

CONTROL(BOTTOM)

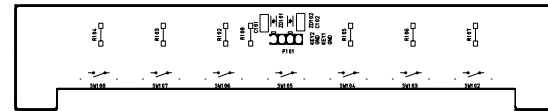

PRE-AMP(TOP)

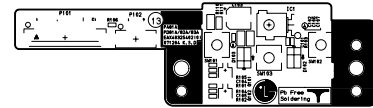

PRE-AMP(BOTTOM)

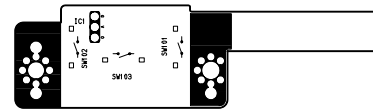



P/NO : MFL41859303

Jan., 2008
Printed in Korea

Depto de Assistência Técnica
Av. D. Pedro I, W7777 - Distrito Industrial
Piracangagua II - Taubaté - SP - Brasil
Cx. Postal 324 - CEP 12.010-970
Tel. : (012) 221-8555 Fax. : (012)221-8550